

# BUCKET CRUSHER EQUIPMENT WITH JAWS ATTACHABLE TO THE EXCAVATOR ARM

PhD. Assoc. Prof. Dorin EFTIMIE  
 "Dunarea de Jos" University of Galati, Romania  
 Eng. Laurentiu BOGOI

## ABSTRACT

*This paper aims to find a new solution of the jaw-action bucket crusher equipment attachable to the excavator arm. The technological operation of crushing needs this type of equipment for enhancing productivity, enlarging the small and medium building work-sites.*

KEYWORDS: crushing equipment, 3D modeling, analysis with finite elements

## 1. INTRODUCTION

Due to its capacity, the "MB" bucket crusher series "B.F. 120.4", (fig.1.) [1] enhances the work efficiency on the small and medium work-sites, having the possibility to lift materials and crush them directly on work-site, in any situation, eliminating the transportation and waste accumulation costs.



Fig.1. Jaw-action bucket crusher equipment

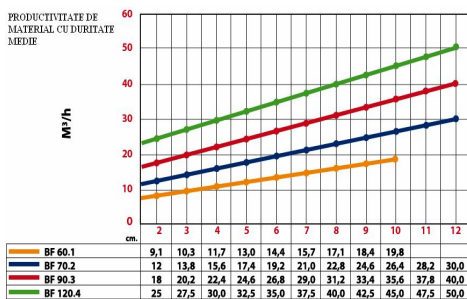

Fig.2. Productivity diagram according to the typo-dimension of the M.B. crushing bucket

In Figure 2 is presented the diagram of productivity with medium hardness of the crushed material, according to the obtained granulation.

## 2. KINEMATIC DIAGRAM

Proper to the jaw-acting crusher with simple articulation, there are the mobile jaw and the fixed jaw. The oscillating movement of the mobile jaw is obtained by involving the rotating movement of the eccentric shaft by the rotating hydraulic engine fitted to the hydraulic system of the excavator.

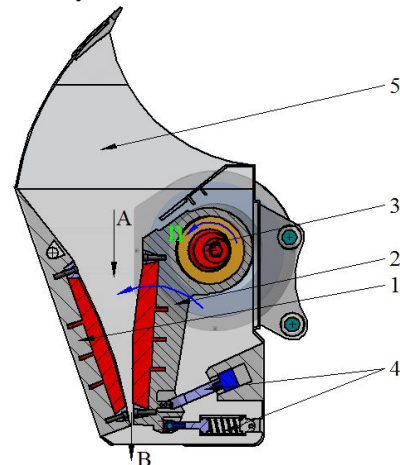

Fig.3. Kinematic Diagram  
 1-fixed jaw; 2- mobile jaw; 3- eccentric shaft;  
 4- elastic elements; 5-bucket body;  
 A-supply; B-evacuation

Depending on the elastic elements of the equipment (position no. 4), it is permitted the crushing and evacuation of some sorts of different granulation sizes (fig.3.).

### 3. HYDRAULIC DIAGRAM

Hydraulic pressure is obtained by the hydraulic variable-delivery pump (position no. 3) which by means of a distributor, activates a rotary hydraulic engine (position no. 6). In its turn, this one transmits the rotating movement to the eccentric shaft of the jaw-acting crusher (position no. 13) (fig.4.)

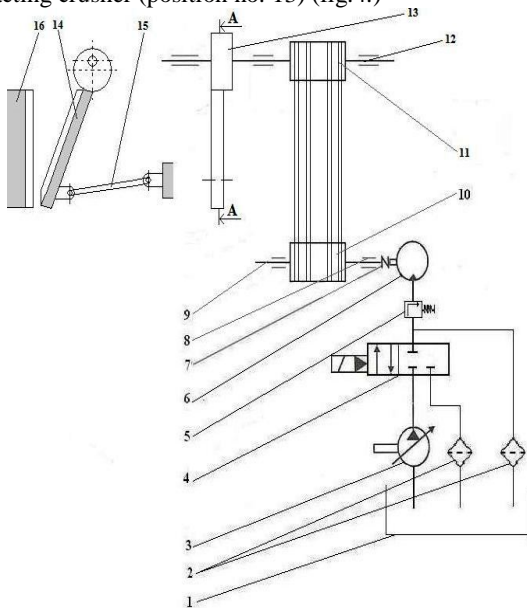

Fig.4. Hydraulic Diagram

- 1. Tank; 2. Filters; 3. Variable-delivery pump;
- 4. Distributor; 5. Safety valve; 6. Rotary hydraulic engine; 7. Clutch; 8. Bearing; 9. Shaft;
- 10. Belt pulley 1; 11. Belt pulley 2; 12. Bearing;
- 13. Eccentric shaft; 14. Mobile jaw;
- 15. Pressure plate; 16. Fixed jaw

### 4. DESCRIPTION, COMPONENTS, FUNCTIONING

In figure 5 a, b is presented the assembly drawing, prototype [2] of crushing equipment whose production capacity is between 5-12 m<sup>3</sup>/h according to the size of the needed grain. The types of materials that can be crushed are included in a wide range: stone, brick, concrete, reinforced-concrete, natural aggregate, slag, asphalt tiles;

Mainly, inside a bucket, it is assembled a crusher with simple articulation, activated by a transmission with trapezoidal belts (position no. 10 and 11). These, on their turn, are activated by a rotary hydraulic engine (position no. 9). The pressure necessary to the hydrostatic engine is taken from the hydraulic installation of the excavator.

It is noted the adjusting system of the crushing sizes (position no. 12, 13, 14) which allow to be obtained some sorts between 20-60 mm. The movement of the mobile jaw is driven by the eccentric shaft mounted in the assembled box (position no. 8).

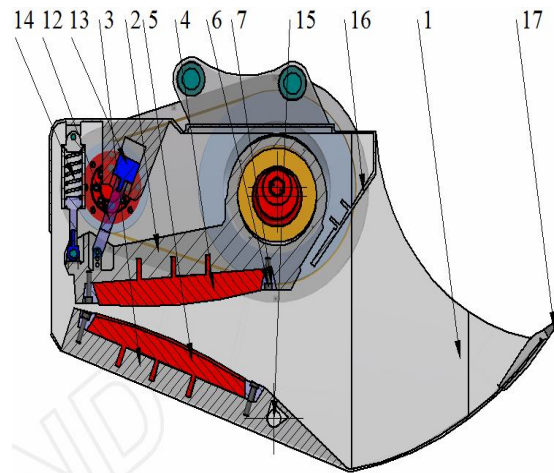

Fig. 5. a. Crusher bucket

- 1-bucket; 2- mobile jaw; 3- fixed jaw;
- 4,5-armoured plate; 6-bolt; 7-collar; 12-cross bar;
- 13-spacer; 14- elastic system; 15-vibrator

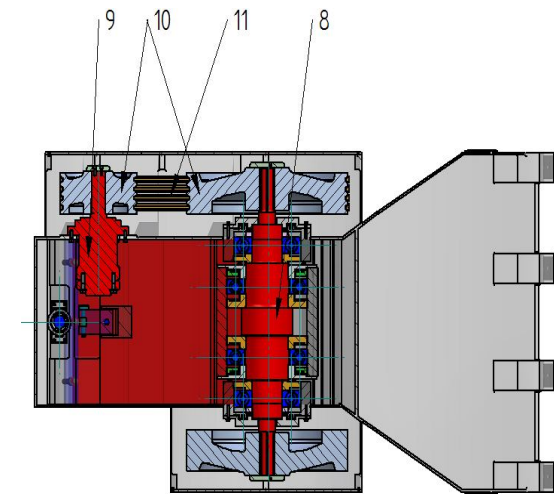

Fig.5. b. Crusher bucket

- 8- Assembled box; 9-Hydroengine; 10- Belt pulley;
- 11- Trapezoidal belts

### 5. DETERMINATION OF THE CRUSHER PRODUCTIVITY

Theoretically, the jaw-action crusher evacuates "n" prisms of material per minute, so, for an hour, we can write:

$$Q_v = 60 V n \tag{1}$$

Where "V" is the volume of the material prism, which can be determined by relation:

$$V = \frac{1}{2} [(s + s_1) + h] \cdot B \cdot l \tag{2}$$

Where:

- > B' = 0.85 B;
- > b - is the width of the crusher mouth opening. [m]
- > s<sub>1</sub> - jaw opening, [m];
- > s - stroke, [m];

It has been adopted this reduction by 15% from the length of the material pieces (B), because the bigger pieces cannot be placed well at the supply hole.

Taking into account that the maximum size of the material pieces is

$d_{max} = D$ , it results:

$$\left(\frac{1}{2}\right)(D + s_1) = d_{med} \quad (3)$$

Where:

➤  $d_{med}$  – is the medium size of the evacuated material pieces

Taking into account the relation ( 2.), it is obtained:

$$V = d_{med} \left(\frac{s}{tg\alpha}\right) B' \quad (4)$$

Coming back to the delivery expression, it results:

$$Q_v = 51\Phi d_{med} n \left(\frac{s}{tg\alpha}\right) B \left[\frac{m^3}{h}\right] \quad (5)$$

This coefficient has values between 0.25...0.65, the last number corresponding to the perfect spherical pieces

Where:

- $h$  – height of the material prism that is evacuated at a rotation, [m]
- $\mu$  - coefficient of material aeration;
- $\gamma$  material volumetric weight  $\left[\frac{daN}{m^3}\right]$ ;
- $n$  – shaft rotation,  $\left[\frac{rot}{min}\right]$ .

## 6. SOLID MODELING OF THE CRUSHER ECCENTRIC SHAFT

Modeling of the eccentric shaft was made by the software called SOLID EDGE 3D, (fig.6.)

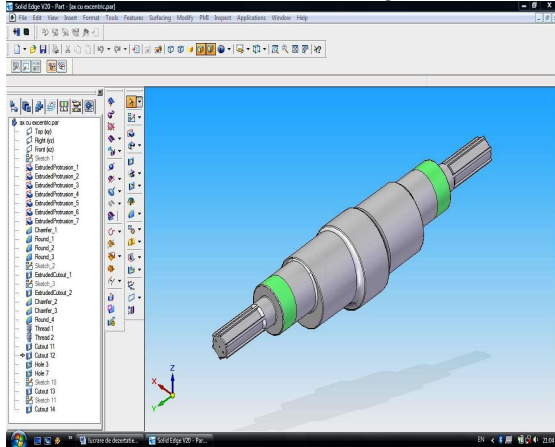

Fig.6. Solid model of the eccentric shaft

### 6.1. ANALYSIS OF THE STATIC TENSION OF THE ECCENTRIC SHAFT USING ALGOR

The modeled eccentric shaft has been introduced in program ALGOR, (fig. 7) [3]

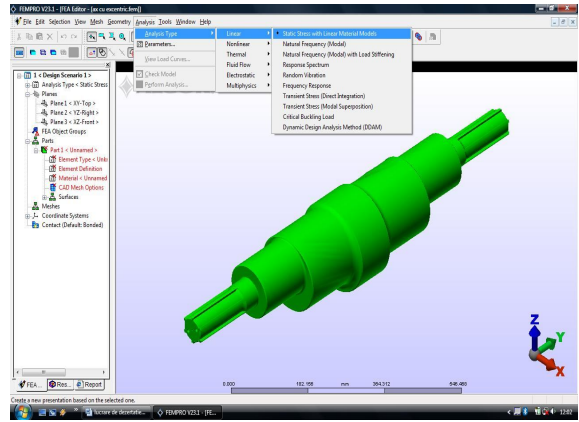

Fig.7. The eccentric shaft is prepared for the analysis of the static tension

### 6.2. DISCRETIZATION OF THE ECCENTRIC SHAFT

Execution of discretization (meshing), eccentric shaft (fig. 8.)

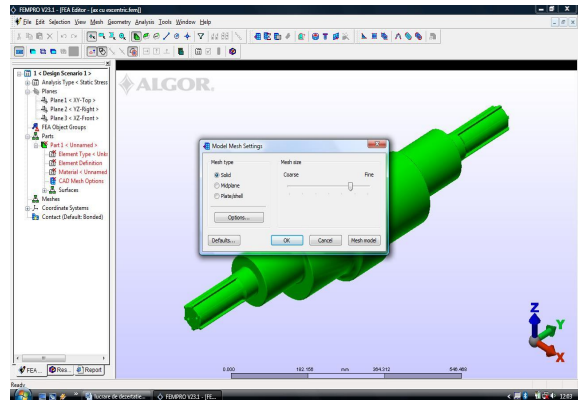

Fig.8. The eccentric shaft is prepared for discretization

### 6.3. RESULT OF DISCRETIZATION

After discretization, the following values were obtained (fig. 9.)

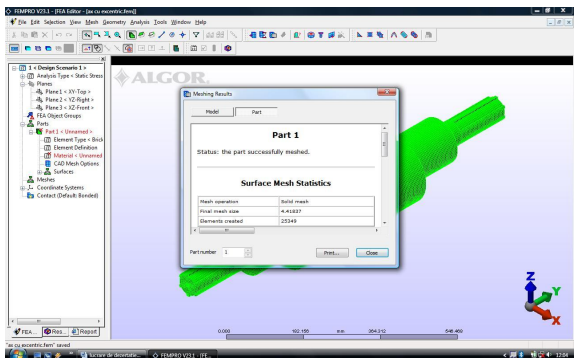

Fig.9. Result of the eccentric shaft discretization

### 6.4. TERMINAL CONDITIONS

The eccentric shaft was built-in where the variances were defined. (fig.10.)

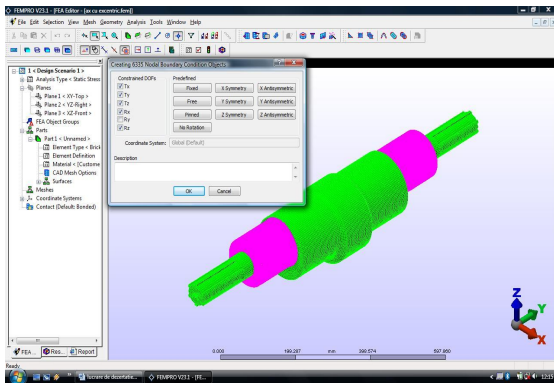

Fig.10. Built-in and defining of the variances

**6.5. APPLICATION OF THE LOADING**

Discretization of the knots and application of the loads are presented in fig .11.

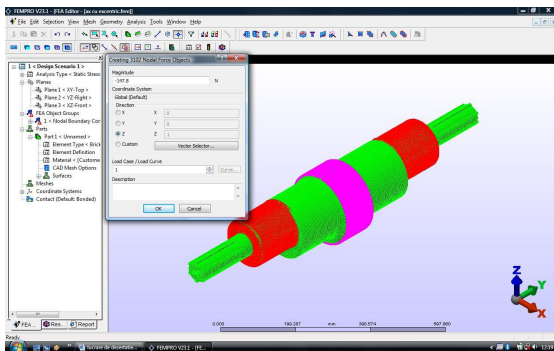

Fig.11. Application of the loads on the discretized knots

**6.6. STATIC ANALYSIS OF RESISTANCE**

As a result of the static analysis of resistance, there have been emphasized the minimum and maximum values of the tensions developed inside the eccentric shaft. (fig.12a,b)

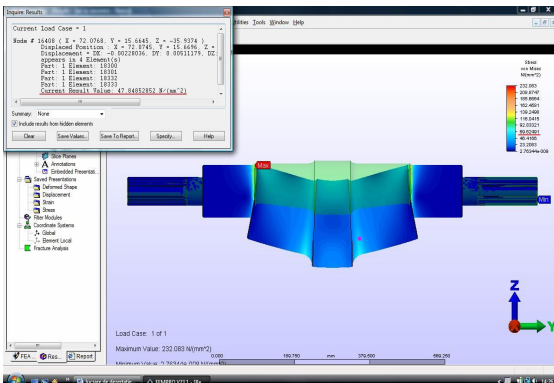

Fig.12.a. Emphasis of the minimum values of the tensions developed inside the eccentric shaft

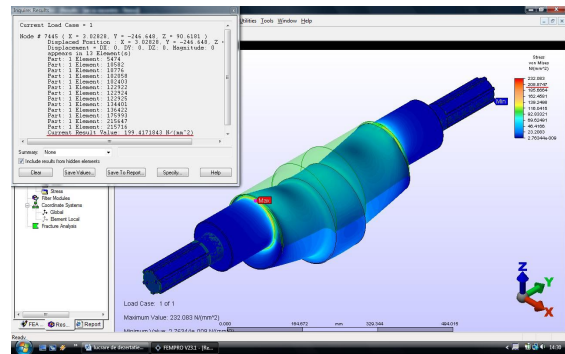

Fig.12.b. Emphasis of the maximum values of the tensions developed inside the eccentric shaft

In figure 13 there are graphically presented the results of the travelling analysis of the tensions developed inside the eccentric shaft.

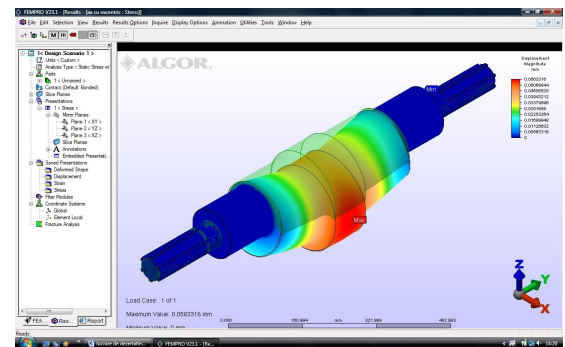

Fig.13. Result of the deformation analysis

**7. CONCLUSIONS**

It has been attempted to elaborate a new solution of crushing equipment attachable to the excavator arm, adaptable to the technological requests taking into account the constructive solutions existing on the market of equipment.

Actually, on worksites, there is the necessity of performing some crushing operations of some sorts of granulations different from the supplied ones.

**REFERENCE**

- [1] <http://www.mecaniccabreganzese.com;>
- [2] [http://solidedge.blogspot.ro/;](http://solidedge.blogspot.ro/)
- [3] <http://download.autodesk.com/us/algortutorials/index.html>